



CORDIS SERIES

High Resolution Proportional
Flow Controller

Operating Instructions



The Cordis CFC series are closed-loop flow controllers designed to maintain a steady and repeatable downstream flow as demand process changes occur. Cordis is available in a compact card style (CFC-C: Card Unit) or with an IP65 rated enclosure (CFC-H: Housed Unit) for manufacturing and industrial environments. Both styles come standard with one Clippard proportional electronic valve.

Content

2	Technical Data	Serial Commands	13
2	Operational Description	Serial Connection - CFC-C	14
3	Mounting	Serial Connection - CFC-H	15
3	Pneumatic Plumbing	Ordering Information & Cables	16
3	Safety & Best Practices	Dimensions - CFC-C	17
4	Calibration	Dimensions - CFC-H	18
4	Recalibration	Contact Information	19
5-8	Electrical Connection	Limited Warranty	19
9	Serial PuTTY Configuration	Other Useful Material Links	19
10-13	Serial Configurations	clippard.com/link/cordis	

Technical Data

ELECTRICAL	
Voltage	15 to 24 VDC
Current Draw	≤ 250 mA max.
Protection Rating	IP65 (housed unit only)
Warm-Up Period	<1 minute
Signal/Command	<i>Electrical:</i> 0.2 to 10 VDC or 4.32 to 20 mA <i>Serial:</i> 3.3 VDC
Turndown Ratio	50 : 1

PERFORMANCE	
Valve Type	Normally-Closed Proportional
Accuracy	≤ 2% of full scale
Resolution	≤ 25 mV
Linearity	≤ 1%
Repeatability	≤ 1%
Linearity	≤ 1%
Max. Hysteresis	≤ 1%
Max. Inlet	60 psig
Flow Range Sensors	0 to 0.03 l/min, 0 to 0.2 l/min, 0 to 0.5 l/min, 0 to 1 l/min, 0 to 4 l/min, 0 to 6 l/min, 0 to 15 l/min
Pressure Drop	≤ 14" H2O
Response Time	< 50 ms typical (<i>application dependent</i>)

WETTED MATERIALS	
Sensor	Polyamide
Manifold	Anodized aluminum
Valves	DVP: Stainless Steel, PPS EVP: ENP Brass
Regulated Supply	ENP Brass
IP65 Housing	Polycarbonate

OPERATING CONDITIONS	
Operating Flow Range	Minimum: 0 to 15 sccm Maximum: 0 to 15 l/min
Operating Temp.	32 to 120°F (<i>0 to 49°C</i>)
Medium	Clean, dry, non-corrosive gases
Port Size	1/8" NPT, G1/8

MORE DETAILS	
Website	clippard.com/link/cordis

Operational Description

The Cordis Flow Controller is designed to accept a constant regulated pressure on the inlet port. The outlet port should be connected to the downstream process side of the application. As the command signal increases the proportional valve modulates open, which allows flow to pass through the internal flow sensor. This flow sensor is constantly providing active feedback to the microcontroller. As soon as the feedback matches the user-specified command, the proportional valve holds the commanded flow. If at any point the sensor measures a higher flow value than the set point or if the user-specified command is lowered, the proportional valve will modulate closed to maintain a stable and accurate flow control in the process. Likewise, if any increased consumption occurs downstream, the proportional valve will modulate open and instantly compensate to maintain desired downstream flow.

Mounting

The Cordis series can be mounted in any orientation without negatively affecting process control. Both the CFC-C and CFC-H models come standard with convenient (top-down) mounting holes for easy mounting to most flat surfaces.

CFC-C Pneumatic Plumbing

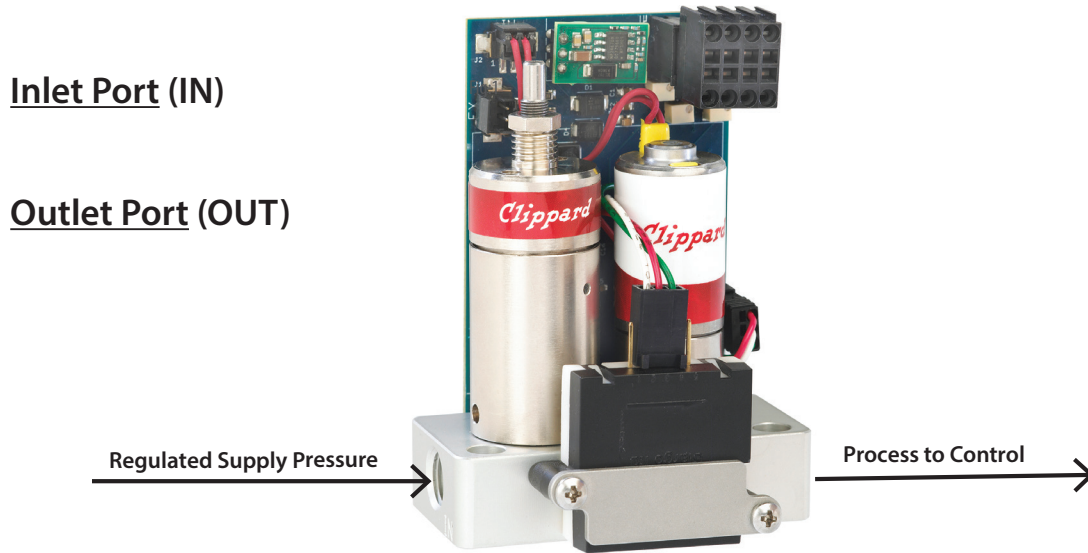

Safety & Best Practices

- ⚠ Inlet pressures >60 psig could damage the flow sensor.
- ⚠ Recommended filtration for supply media is 40 micron or better.
- ⚠ Supply pressure dependent on calibrated flow range.
- ⚠ Disconnect power if supply pressure is not connected.
- ⚠ When changing fittings, thoroughly clean all tape and/or debris from the port connections.
- ⚠ Properly regulated inlet directly affects accuracy of flow controller.
- ⚠ Preferred sealant for 1/8" NPT ports is Loctite 545 or face seal. If thread tape is required, make sure to start wrap after the first two threads to reduce the possibility of valve contamination.
- ⚠ Always take precautionary measures while handling exposed circuit boards: Hold circuit board on edges whenever handling device. Store device in anti-static bag to prevent possible ESD from damaging circuitry.

Calibration

The calibration of the Cordis series is done at the time of manufacture to NIST traceable standards. Each unit is calibrated and the PIDs are set to the Cordis standard tuning. If a customer's specific application details are known prior to manufacture (recommended), the PIDs will be tuned in accordance with the known specifications to provide the most stable and repeatable control. Below are the available calibration ranges.

Calibrated Flow Ranges

CALIBRATED FLOW
0 to 0.03 l/min / 0 to 30 sccm
0 to 0.2 l/min / 0 to 200 sccm
0 to 0.5 l/min / 0 to 500 sccm
0 to 1.0 l/min / 0 to 1,000 sccm
0 to 4.0 l/min / 0 to 4,000 sccm
0 to 6.0 l/min / 0 to 6,000 sccm

Recalibration

The Cordis series does not require recalibration during its lifetime. If the calibration needs to be changed and/or modified, the unit must be returned to Clippard or completed by a certified field technician. Any attempt to recalibrate in the field without prior authorization will void the warranty.

Please contact Clippard for all Return Material Authorization (RMA) requests:

Clippard

7390 Colerain Avenue | Cincinnati, OH 45239 | sales@clippard.com | 1-877-245-6247

Please have the serial number(s) available for reference.

0 to 10 VDC Electrical Connection | CFC-C



Make sure AC power is disconnected before DC connections are made

The Cordis requires 15 to 24 VDC on **Pin 1** of the electrical connector. It uses 0 to 10 VDC command signal on **Pin 3** of the electrical connector. The power supply ground, command source ground and **Pin 2** must be tied together. If the analog monitor signal is being used, utilize **Pin 4** to send the 0 to 10 VDC signal to a measuring device like a volt meter, panel meter or acquisition device.

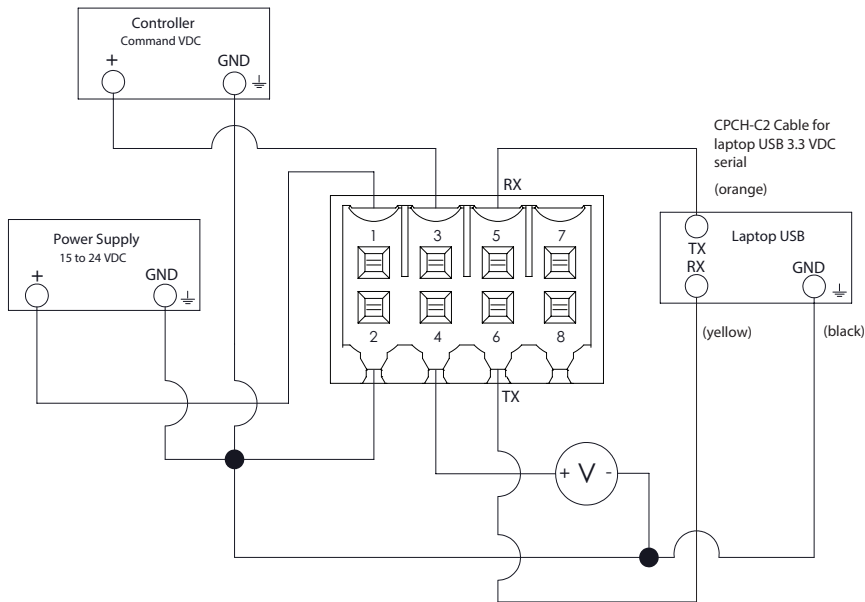

CFC-C Model Electrical Pin-out

PIN NUMBER	FUNCTION	COLOR
1	Power, 15-24 VDC	Red
2	DC Common/Ground	Green
3	+Command Input	White
4	Analog VDC Output	Black
5	3.3 VDC Serial RX	Blue
6	3.3 VDC Serial TX	Brown
7	Not Used	Pink
8	Not Used	Yellow

Red LED: Power to Unit ON
Solid Blue LED: Analog Mode
Flashing Blue LED: 3.3 VDC Serial Mode

Reference Serial Configuration Section for Command Change Instructions

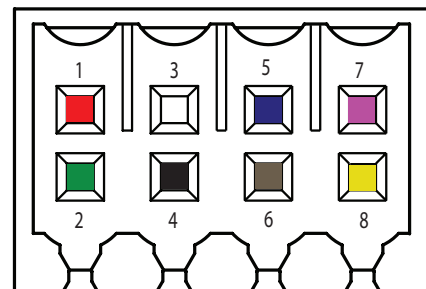

0 to 10 VDC Electrical Connection | CFC-H

! Make sure AC power is disconnected before DC connections are made

The Cordis requires 15 to 24 VDC on **Pin 1** of the electrical connector. It uses 0.2 to 10 VDC command signal on **Pin 3** of the electrical connector. The power supply ground, command source ground and **Pin 2** must be tied together. If the analog monitor signal is being used, utilize **Pin 4** to send the 0.2 to 10 VDC signal to a measuring device like a volt meter, panel meter or acquisition device.

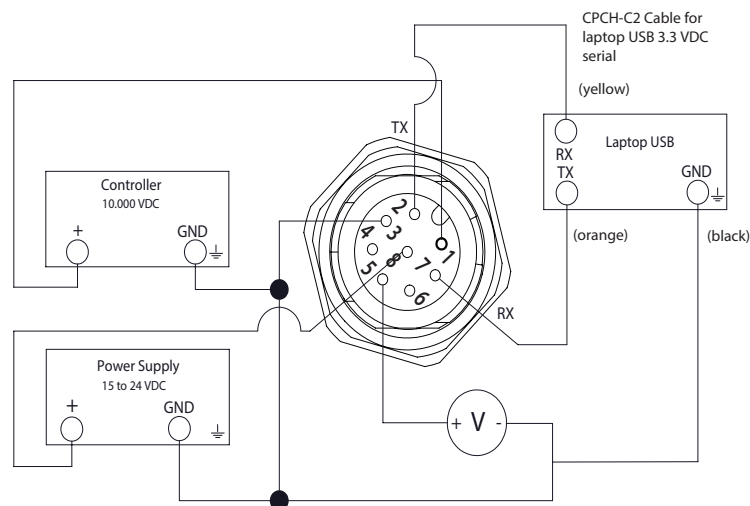

CFC-H Model Electrical Pin-Out

PIN NUMBER	FUNCTION	COLOR
1	Power, 15-24 VDC	Red
2	DC Common/Ground	Green
3	+Command Input	White
4	Analog VDC Output	Black
5	3.3 VDC Serial RX	Blue
6	3.3 VDC Serial TX	Brown
7	Not Used	Pink
8	Not Used	Yellow

Red LED: Power to Unit ON
Solid Blue LED: Analog Mode
Flashing Blue LED: 3.3 VDC Serial Mode

Reference Serial Configuration Section for Command Change Instructions

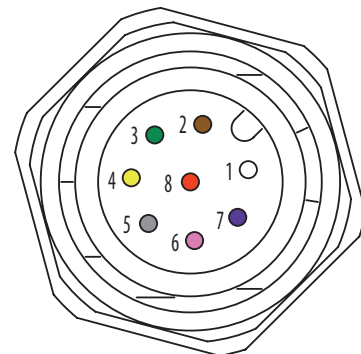

0 to 10 VDC Electrical Connection | CFC-H

! Make sure AC power is disconnected before DC connections are made

The Cordis requires 15 to 24 VDC on **Pin 8** of the electrical connector. It uses 0.2 to 10 VDC command signal on **Pin 1** of the electrical connector. The power supply ground, command source ground and **Pin 3** must be tied together. If the analog monitor signal is being used, utilize **Pin 5** to send the 0.2 to 10 VDC signal to a measuring device like a volt meter, panel meter or acquisition device.

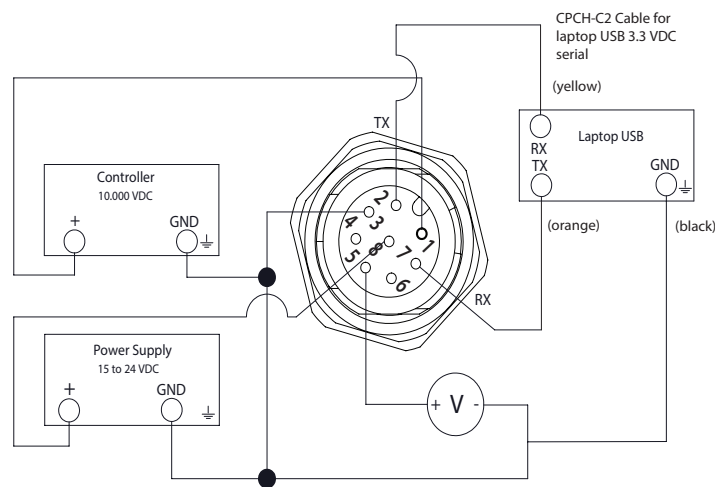

CFC-H Model Electrical Pin-Out

PIN NUMBER	FUNCTION	COLOR
1	+Command Input	White
2	3.3 VDC Serial TX	Brown
3	DC Common/Ground	Green
4	Not Used	Yellow
5	Analog VDC Output	Gray
6	Not Used	Pink
7	3.3 VDC Serial RX	Blue
8	Power, 15-24 VDC	Red

Red LED: Power to Unit ON
Solid Blue LED: Analog Mode
Flashing Blue LED: 3.3 VDC Serial Mode

Reference Serial Configuration Section for Command Change Instructions

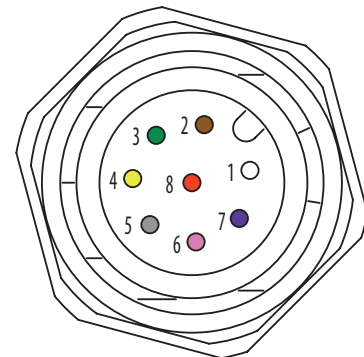

4-20 mA Electrical Connection

! Make sure AC power is disconnected before DC connections are made

The Cordis requires 15 to 24 VDC on **Pin 8** of the electrical connector. It uses 4.32 to 20 mA command signal on **Pin 6** of the electrical connector. Connect **Pin 4** to DC common or negative 4.32 to 20 mA on the control module. If the analog monitor signal is being used, utilize **Pin 5** to send the 4.32 to 20 mA signal to a measuring device like a mA meter, panel meter or acquisition device.

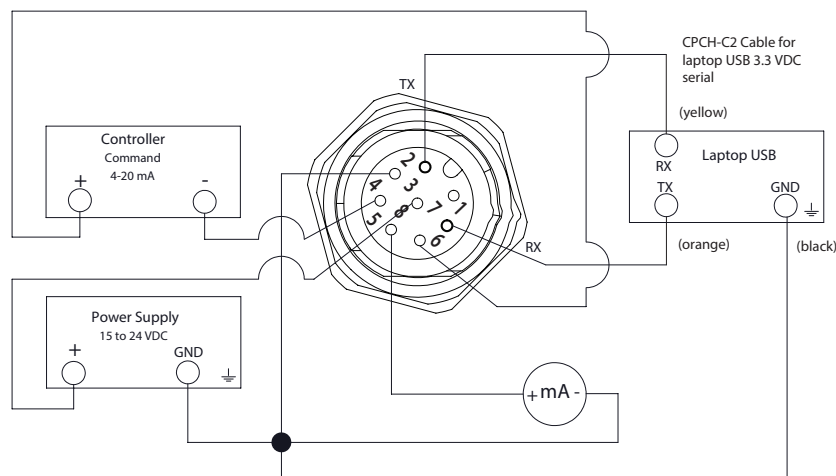

CFC-C Model Electrical Pin-Out

PIN NUMBER	FUNCTION	COLOR
1	n/c	White
2	3.3 VDC Serial TX	Brown
3	DC Common/Ground	Green
4	-4.32 to 20 mA Command Return	Yellow
5	4.32 to 20 mA Output	Gray
6	+4.32 to 20 mA Command Input	Pink
7	3.3 VDC Serial RX	Blue
8	Power, 15-24 VDC	Red

Red LED: Power to Unit ON
Solid Blue LED: Analog Mode
Flashing Blue LED: 3.3 VDC Serial Mode

Reference Serial Configuration Section for Command Change Instructions

Fig:5

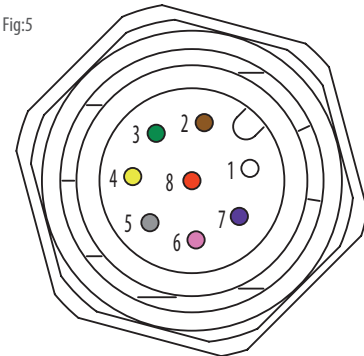

Serial Configuration



Cordis utilizes a 3.3 VDC communication signal

To communicate via Serial with the Cordis, software is required. Many serial software communication solutions are available. If you already have a software solution, please ensure it is configured with the specifications listed below prior to making the electrical connections to Cordis. The commands can be found on Page 13.

If you do not already have a serial software solution, we recommend PuTTY as a free and open-source solution. PuTTY is one of the most common software packages used for serial communication and can be downloaded here: <https://putty.org/>

Once downloaded and installed on your windows based machine, please follow the steps below to configure the software prior to making the electrical connections to Cordis. The specifications we will configure and/or confirm within PuTTY are listed.

Serial Software Configuration (PuTTY)

SETTING LABEL	SPECIFICATION
Speed (baud)	57600
Data Bits	8
Stop Bits	1
Parity	None
Flow Control	None
Serial Line	See Steps 1 & 2

Serial Configuration | Continued

STEP - 1

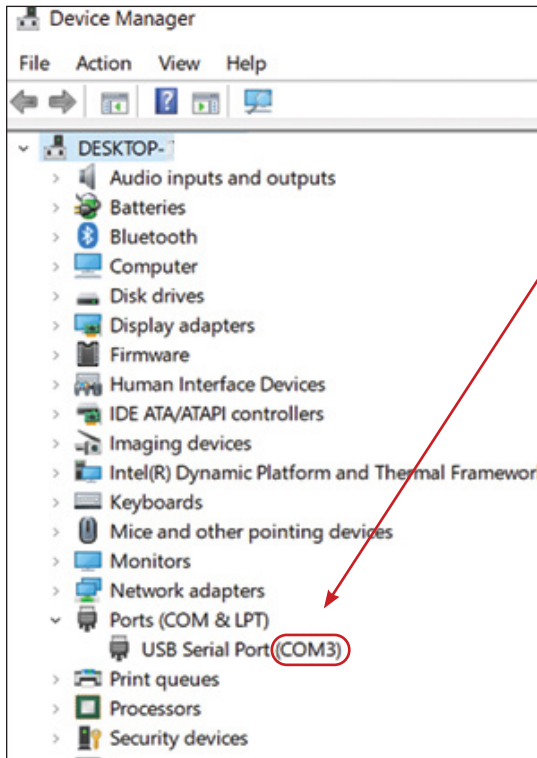

- 1) Ensure proper serial connection to Cordis unit and then connect 3.3 VDC serial to the control device. The wiring schematics can be found on pages 14 and 15.
- 2) Open Device Manager and identify the serial port assigned to the serial cable.

>>> Many ways to open Device Manager:
<https://www.digitalcitizen.life/ways-open-device-manager-windows>

STEP - 2

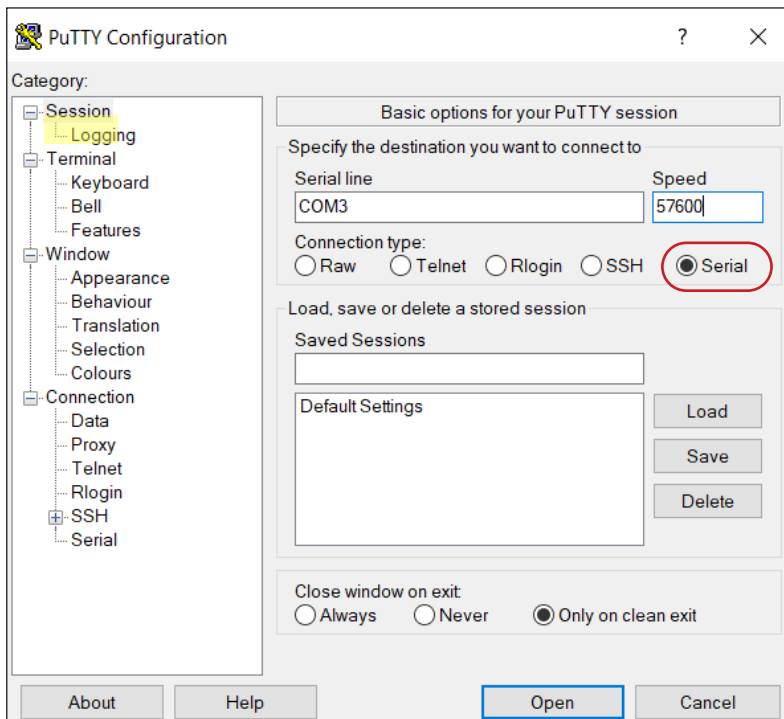

- 1) Open installed Putty program
- 2) Ensure 'Serial' is selected

Serial Configuration | Continued

STEP - 3

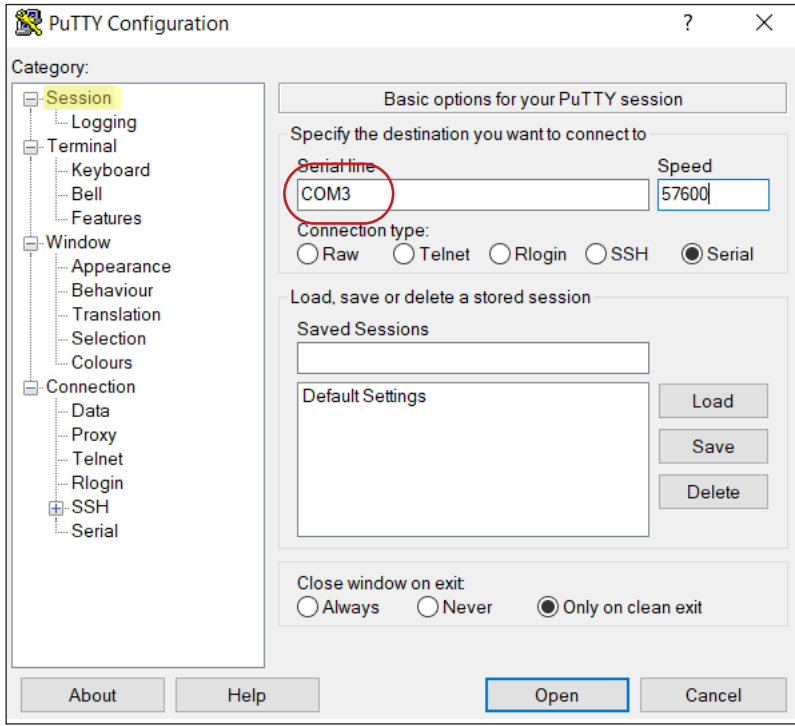

Input the port identified in Step - 1 into the Serial Line as shown.

STEP - 4

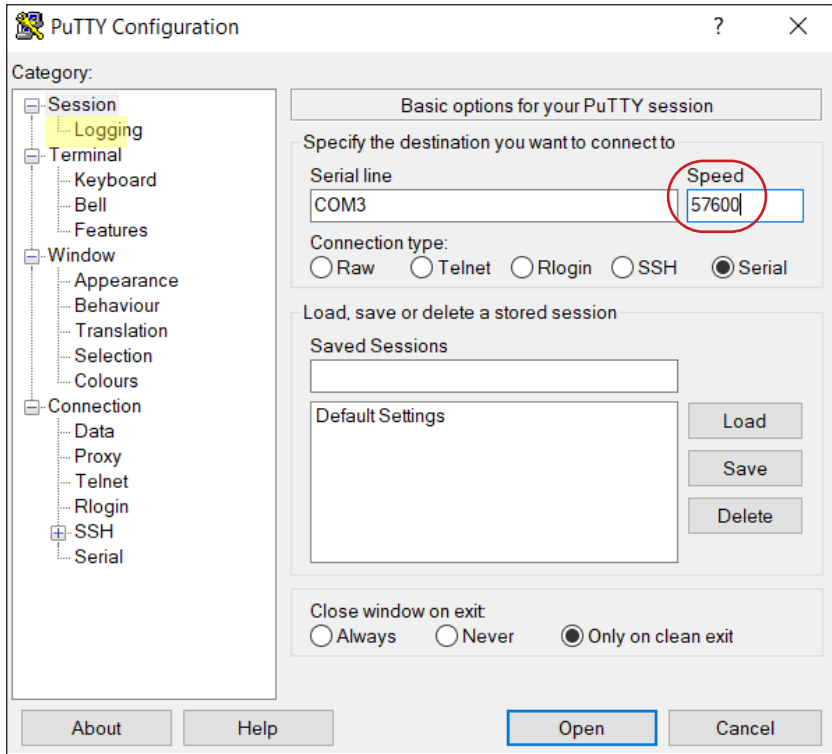

Change the speed (baud) setting to: **57600**

Serial Configuration | Continued

STEP - 5

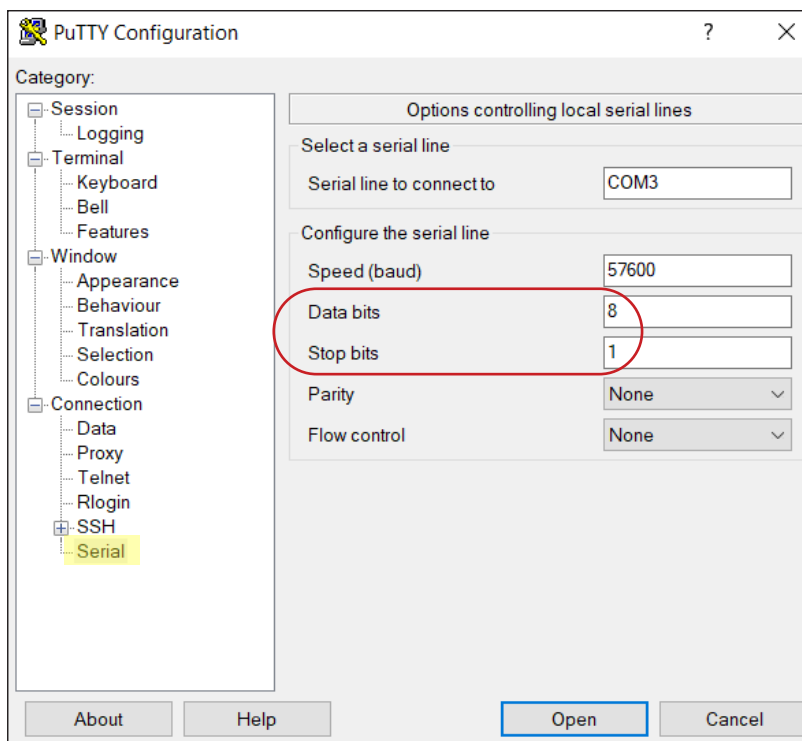

Change **Data Bits** to 8
and **Stop Bits** to 1

STEP - 6

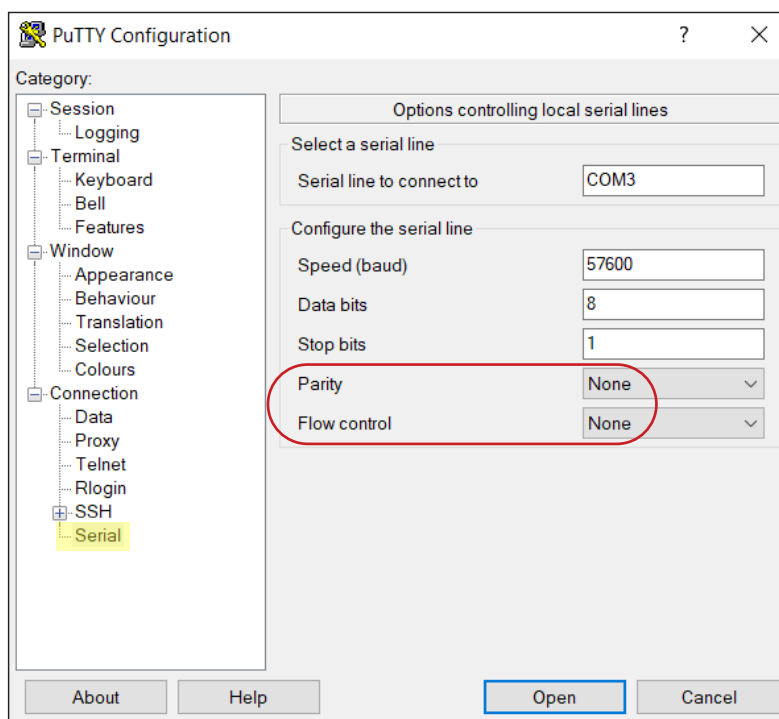

Ensure both **Parity** and **Flow Control** are set to None

Serial Configuration | Continued

STEP - 7

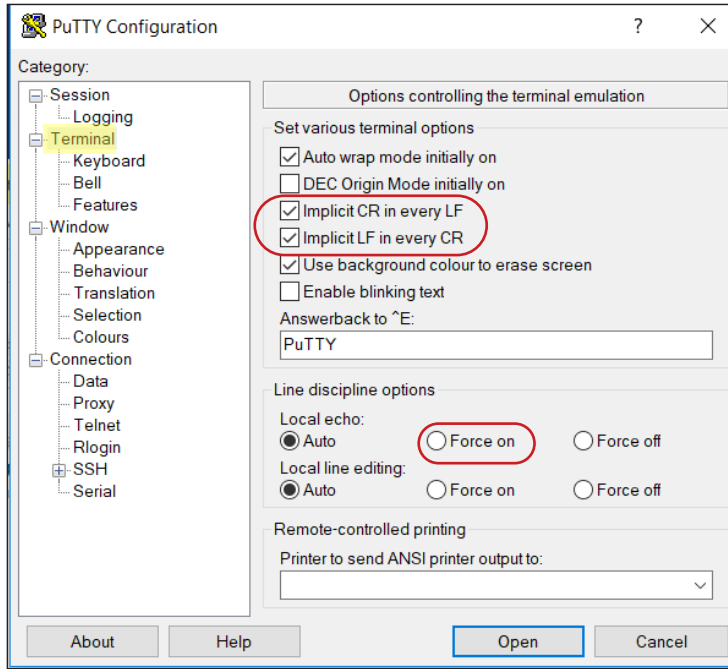

In Terminal settings, check the box for: **Implicit CR in every LF & Implicit LF in every CR**

STEP - 8

Once the Cordis is connected and the software is configured, the below commands can be used to change settings, request feedback and control the device.

Note: If you would like feedback as you type, set the Local Echo to "Force On"

Serial Commands

Cordis | Serial Commands

DESCRIPTION	COMMAND ABBREVIATION	INSERT TO SEE CURRENT VALUES	INSERTED EXAMPLE CHANGES	READABLE	WRITABLE
Model No.	ID	?ID	n/a	Y	N
Serial Number	SN	?SN	n/a	Y	N
Proportional "P" Value	PIDP	?PIDP	PIDP: 100	Y	Y
Integral "I" Value	PIDI	?PIDI	PIDI: 0.75	Y	Y
Command Type (0=Analog, 1=Digital)	CT	?CT	CT: 1	Y	Y
Current Command (0 - 100% of Full Scale)	CC	?CC	CC: 50	Y	Y
Monitor Output Signal from Internal Sensor	MON	?MON	n/a	Y	N
Save Settings to ROM	SAVE	n/a	SAVE	N	Y



When entering all Reading Commands, always prefix with "?". Example: ?CC



Make sure to leave one space between the colon and value when making changes. Example: CC: 50

Serial Connection | CFC-C

! Make sure AC power is disconnected before DC connections are made

The Cordis requires 15 to 24 VDC on **Pin 1** of the electrical connector. It uses serial communication on **Pin 5** to receive and **Pin 6** to send digital responses. The power supply ground, command source ground and **Pin 2** must be tied together.

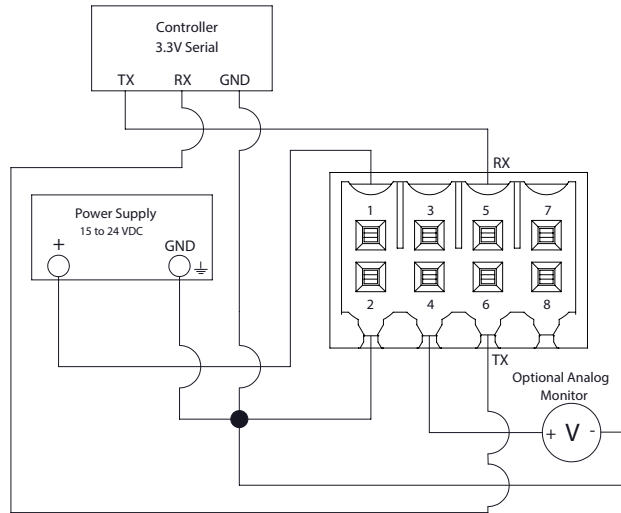

! The 3.3 VDC host RX connects to the device TX. The 3.3 VDC host TX connects to the device RX. Be sure the 3.3 VDC host ground is common with the device ground.

CFC-C Model Electrical Pin-out

PIN NUMBER	FUNCTION	COLOR
1	Power, 15-24 VDC	Red
2	DC Common/Ground	Green
3	+Command Input	White
4	Analog VDC Output	Black
5	3.3 VDC Serial RX	Blue
6	3.3 VDC Serial TX	Brown
7	Not Used	Pink
8	Not Used	Yellow

Red LED: Power to Unit ON
Solid Blue LED: Analog Mode
Flashing Blue LED: 3.3 VDC Serial Mode

Reference Serial Configuration Section for Command Change Instructions

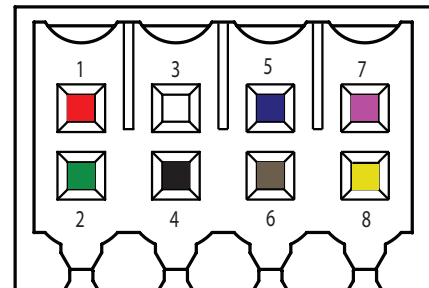

Serial Connection | CFC-H

⚠ Make sure AC power is disconnected before DC connections are made

The Cordis requires 15 to 24 VDC on **Pin 8** of the electrical connector. It uses serial communication on **Pin 7** to receive and **Pin 2** to send digital responses. The power supply ground, command source ground and **Pin 3** must be tied together.

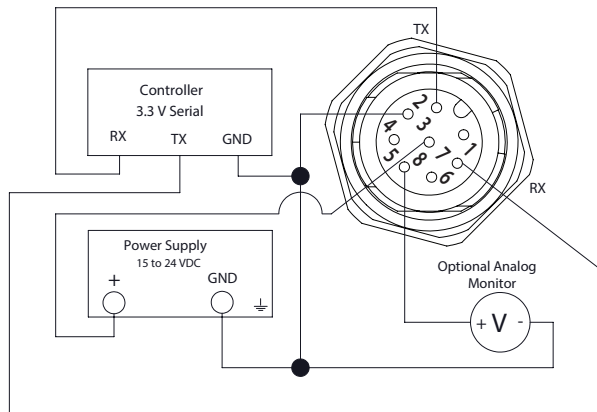

CFC-H Model Electrical Pin-out

PIN NUMBER	FUNCTION	COLOR
1	+Command Input	White
2	3.3 VDC Serial TX	Brown
3	DC Common/Ground	Green
4	Not Used	Yellow
5	Analog VDC Output	Gray
6	Not Used	Pink
7	3.3 VDC Serial RX	Blue
8	Power, 15-24 VDC	Red

Red LED: Power to Unit ON
Solid Blue LED: Analog Mode
Flashing Blue LED: 3.3 VDC Serial Mode

Reference Serial Configuration Section for Command Change Instructions

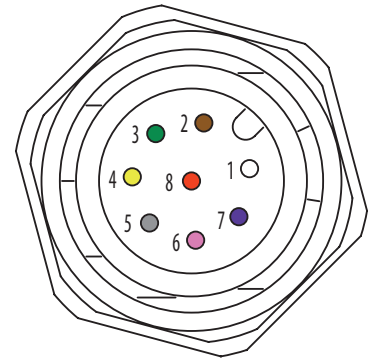

Ordering Information

Model	Type	Porting	Signal/Command	Regulated Supply	Supply Pressure	Calibrated Flow Range
CFC- Flow Control	C Card Unit	F 1/8" NPT	E 0.2 to 10 VDC	-A No Regulator	A 5 to 10 psig	A 0 to 0.03 l/min
	H Housed Unit	G G1/8	R 3.3 VDC Serial	-B Clippard DR-2 Regulator	B 11 to 20 psig	B 0 to 0.2 l/min
			I 4.32 to 20 mA		C 21 to 30 psig	C 0 to 0.5 l/min
					D 31 to 40 psig	D 0 to 1 l/min
					E 41 to 50 psig	E 0 to 4 l/min
					F 51 to 60 psig	F 0 to 6 l/min

Example Part No.	CFC-CFE-BAC
-------------------------	-------------

Accessories | Cables



<<CPCH-C1 Molded Actuation Cable, 8-Pin, 6'



<<CPCH-C2 3.3 VDC Serial Cable, 3'



<<CPCH-CA6 Power Cord, 8-Pin, 6' (card unit only)

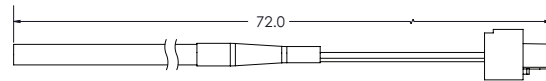

Accessories | Mounting Bracket

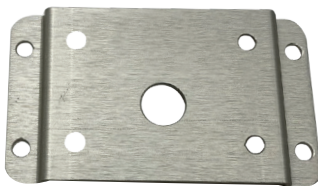

<<CPCH-B2 Mounting Bracket (for use with Housed unit)

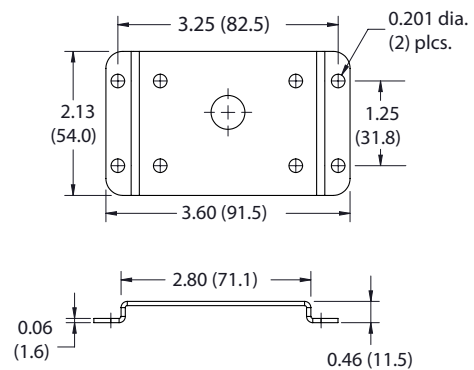

Dimensions | CFC-C

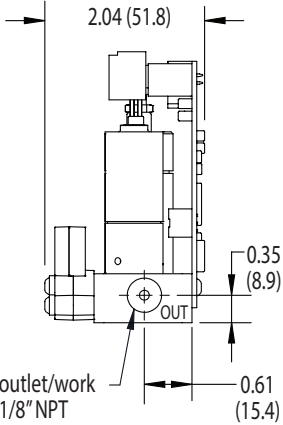
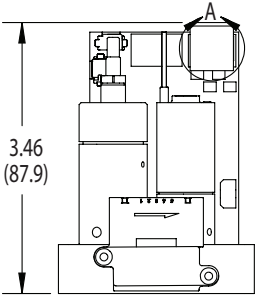
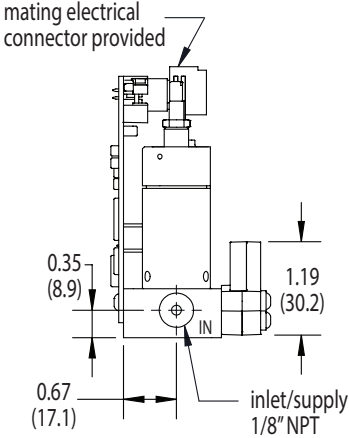
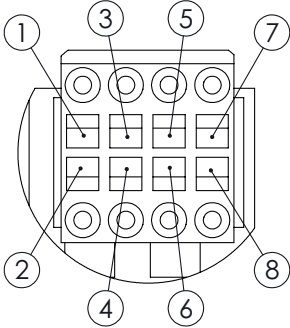
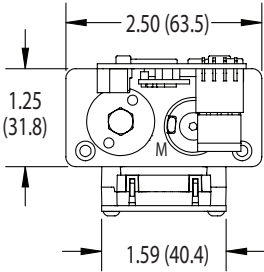
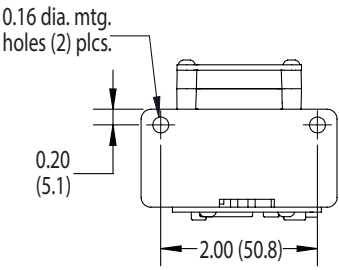
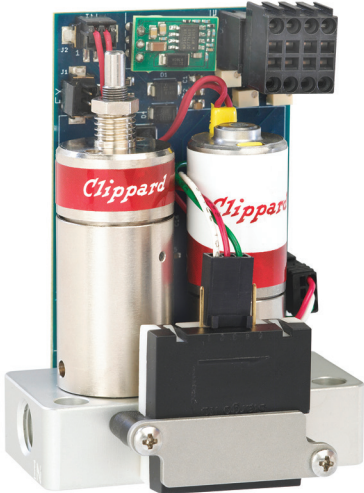

Dimensions | CFC-H

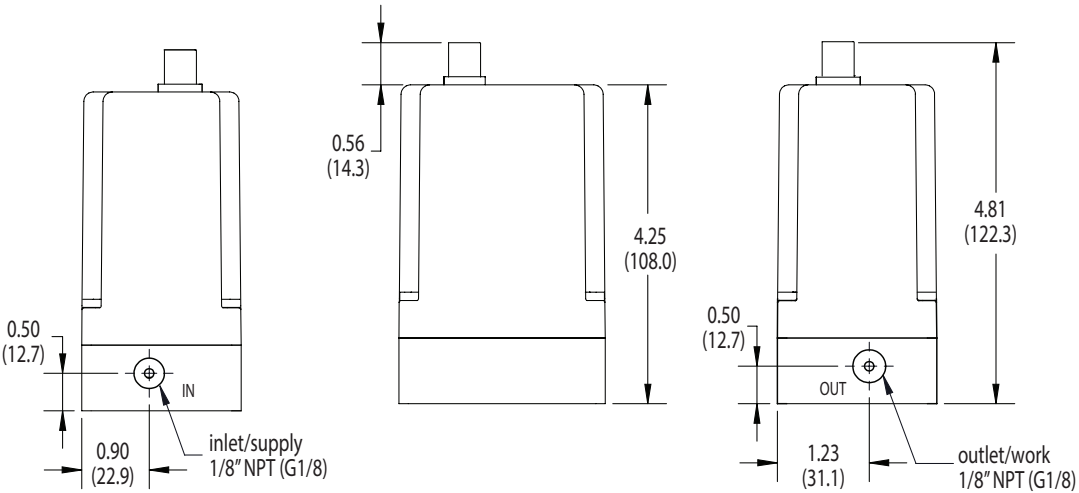
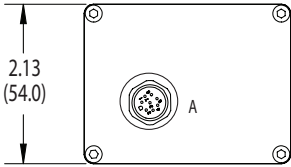
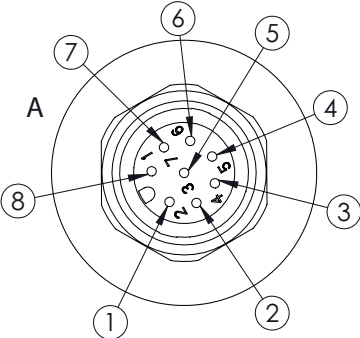



7390 Colerain Avenue
Cincinnati, OH 45239

1-513-521-4261
1-877-245-6247

Cordis, of the heart

Other Useful Materials

Digital vs. Analog Control White Paper

Pressure vs. Flow Control White Paper

Resolution in Proportional Control White Paper

View Frequently Asked Questions

View Web Site

Limited Warranty

All information contained in this publication is for reference only. Proper design engineering procedures should be used to assure any compliances. Clippard Instrument Laboratory, Inc. reserves the right to make changes without notice and does not warrant or guarantee the information contained herein.

Clippard Instrument Laboratory, Inc. (Seller) warrants its products to be free from defects in material and workmanship for a period of one (1) year from the date of sale. Seller's liability shall be limited at seller's option to repair, replace or refund purchase price of product found by seller's examination to be defective. All claims under this warranty must be made in writing to seller's factory sales department giving full details, prior to return of product, postpaid, to factory. Seller shall not be responsible for product failure due to normal wear, accident, buyer's misapplication, abuse, neglect or alteration of product. Seller will not be responsible for any consequential damages. Clippard makes no other warranty of any kind, expressed or implied. Circuits shown in this catalog are for instructional purposes only. All circuits used on equipment and machinery should be thoroughly tested by qualified personnel under actual working conditions to determine their suitability for buyer's intended use. All technical data and operations are average values based on standard production models. Some deviations can be expected and considerations should be given during initial design stages. All operating characteristics are based on new equipment, under normal conditions of use and environments and oil free air supply. Dimensions stated may be nominal and are subject to change without notice. Contact Clippard for specific dimensional tolerances when dimensions are critical.

Proudly made in the USA.